



Construction

Close coupled electric submersible pumps.

GMC: with single-channel impeller.

GMV: with free-flow (vortex) impeller.

Double mechanical shaft seal with interposed oil chamber, to protect against dry-running.

Applications

For domestic or industrial waste water, dirty water with solids up to 45 mm grain size for GMC and 50 mm for GMV, for liquids which are compatible with the pump materials.

Operating conditions

Liquid temperature up to 35 °C.

pH value: 6-11.

Maximum immersion depth: 10 m (with suitable cable length).

Continuous duty (with submerged motor).

Motor

2-pole induction, 50 Hz (n = 2900 rpm).

GMC, GMV: three-phase 230 V ± 10%;
three-phase 400 V ± 10%;
2 built-in thermal protectors to be connected to a control box.

Cable: 4G1,5 mm²+ 2x0,5 mm², length 10 m.

GMCM, GMVM: single-phase 230 V ± 10%.

With float switch, built-in thermal protector and built-in capacitor.

Cable: H07RN8-F, 3G1,5 mm², length 10 m, with plug (CEI - UNEL 47166).

Insulation class F. Protection IP X8.

Triple impregnation, humidity-proof winding.

Constructed in accordance with: EN 60335-2-41.

Materials

Component	Material
Pump casing	Cast iron GJL 200 EN 1561
Casing cover	
Impeller	
Motor housing	
Motor cover	
Shaft	Chrome steel 1.4016 EN 10088 (AISI 430)
Mechanical seal: Upper	Carbon, ceramic, NBR
Lower	
Seal lubrication oil	Oil for food machinery and pharmaceutical use

Characteristic curves n ≈ 2900 rpm

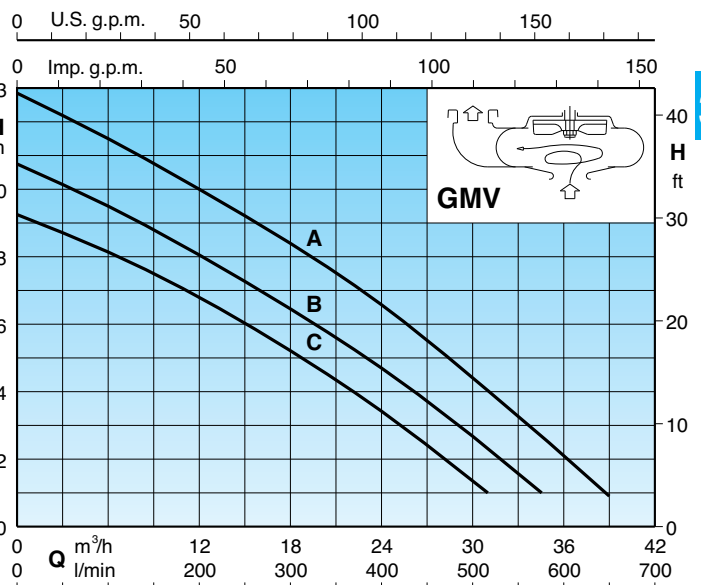
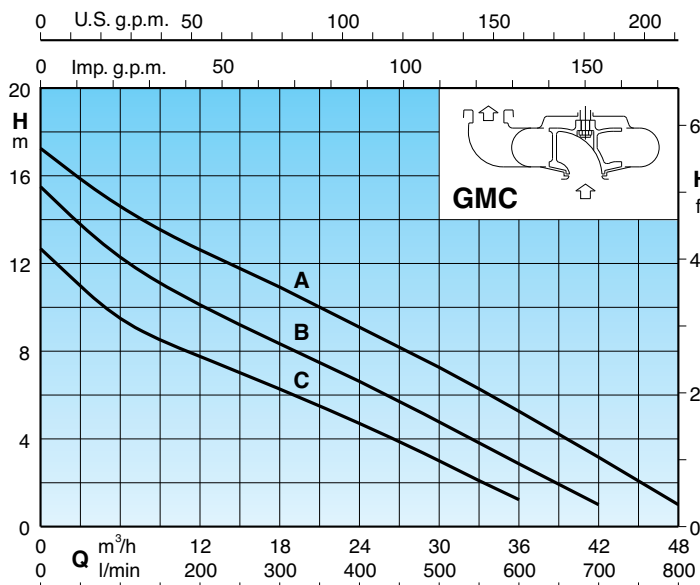

Performance $n \approx 2900$ rpm

3~	230 V 400 V		1~	230 V	P ₁	P ₂		Q	6	12	18	24	30	36	42	48	
	A	A				A	kW		kW	HP	m ³ /h	l/min	100	200	300	400	500
GMC 50CE GMC 50-65C	3,3	1,9	GMCM 50CE GMCM 50-65C	4,5	1,1	0,75	1	H m	9,5	8	6,5	5	3	1			
GMC 50BE GMC 50-65B	4,8	2,7	GMCM 50BE GMCM 50-65B	6,5	1,5	1,1	1,5		12,5	10	8,5	6,5	5	3	1		
GMC 50AE GMC 50-65A	6,6	3,8				1,5	2		14,5	12,5	11	9	7,5	5,5	3	1	

3~	230 V 400 V		1~	230 V	P ₁	P ₂		Q	6	12	18	24	30	31	35	39	
	A	A				A	kW		kW	HP	m ³ /h	l/min	100	200	300	400	500
GMV 50CE GMV 50-65C	3,3	1,9	GMVM 50CE GMVM 50-65C	4,5	1,1	0,75	1	H m	8	7	5	3,5	1,5	1			
GMV 50BE GMV 50-65B	4,8	2,7	GMVM 50BE GMVM 50-65B	6,5	1,5	1,1	1,5		9,5	8	6,5	4,5	2,5	2,3	1		
GMV 50AE GMV 50-65A	6,6	3,8				1,5	2		11,5	10	8,5	6,5	4,3	4	2,5	1	

P₁ Max. power input.

H Total head in m.

Density $\rho = 1000$ kg/m³.

Kinematic viscosity $\nu = \max 20$ mm²/sec.

P₂ Rated motor power output.

Dimensions and weights

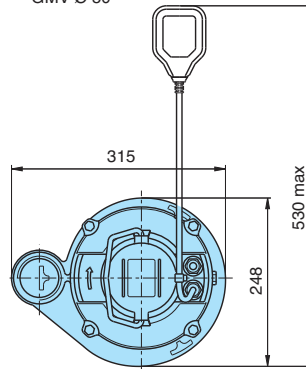
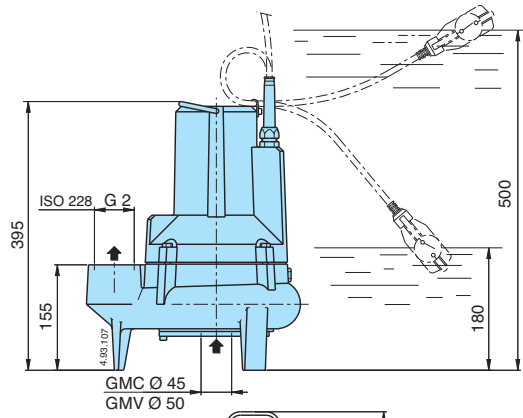

	kg
GMV 50CE	27
GMV 50BE	28
GMV 50AE	29,5
GMVM 50CE	27
GMVM 50BE	28,5

	kg
GMC 50CE	28
GMC 50BE	29
GMC 50AE	30,5
GMCM 50CE	28
GMCM 50BE-	29,5

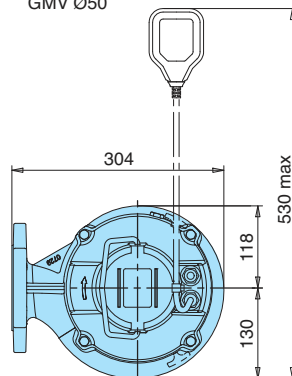
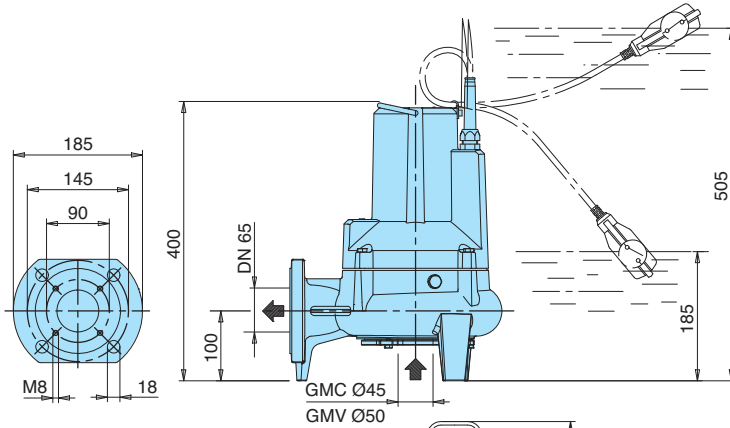

	kg
GMV 50-65C	29
GMV 50-65B	30
GMV 50-65A	31,5
GMVM 50-65C	29
GMVM 50-65B	30,5

	kg
GMC 50-65C	30
GMC 50-65B	31
GMC 50-65A	32,5
GMCM 50-65C	30
GMCM 50-65B	31,5

Dimensions with duck foot coupling

